

Pressure relief valves

Type DB700/1000

NG 6

up to 25 l/min, up to **1000 bar**

Features

- Directly operated
- High degree of pressure stability
- Safe function
- Flat characteristic
- Preset valves on request
(Safety instruction: set at a flow rate of 2 l/min, mineraloil HLP VG15, at higher flow rates, the set pressure increases in accordance with the characteristic of the valve (p. 11/12))
- Back pressure compensated version available
- Poppet tight

Applications

- Pressure limitation in a dynamic pressure system

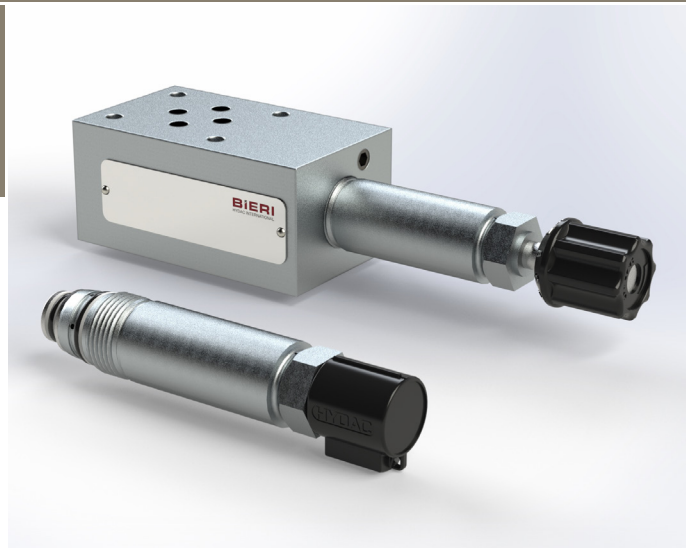

Design

- As cartridge
- As panel mount for mounting directly into the tank
- As modular valve with one cartridge
- Seat construction
- The system pressure can be set to the required pressure via the adjusting spindle
- Pressure adjustment possible over the entire pressure range
- Fixing of the pre-set maximum pressure by lock nut
- Stable control behaviour thanks to damping piston

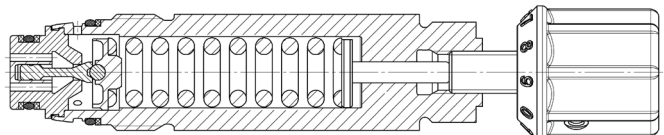

Technical data

Hydraulic fluid	mineral oil according to DIN 51524 (other fluids on request)	
Fluid temperature range	- 20 to 80 °C	
Ambient temperature range	- 30 to 50 °C	
Viscosity range	5 to 400 mm ² /s	
	1000 bar:	NG 6 acc. to Bieri standard
	700 bar:	NG 6 acc. to DIN 24340 / ISO 4401 / CETOP RP 121 H
Max. operating pressure connection P, A, B	700 or 1000 bar	
Max. operating pressure connection T	350 bar, nominal pressure with back pressure compensated version	
Max. flow rate	1000 bar:	16 l/min
	700 bar:	25 l/min
Filtration (recommendation)	according to NAS 1638 class 6 resp. ISO / DIN 4406 17/15/12	
Weight	see overview "Product information"	
Material	modular subplate:	steel zinc-nickel coated
	cartridge body:	stainless steel
	sealing cap:	plastic

Type code

Example	DB	1000	-	6B	-	P	-	1000	-	F	-	A	-	V	-	A		00
Pressure relief valves																		
Size	700 bar			1000 bar														
Nominal size	6 ...																	
Modular subplate valve																		
Connection Bieri	(for 1000 bar) ... B																	
Connection ISO	(700 bar) ... I																	
Cartridge																		
Connection thread metric	... M																	
Design																		
E	cartridge																	
G	panel mount																	
P	modular subplate valve from P to T																	
A	modular subplate valve from A to T																	
AB	modular subplate valve from A to T, B to T																	
PA	modular subplate valve from P to T, A to T																	
Max. setting pressure	700 bar			1000 bar			xxx bar (preset valves)*											
Control method																		
F	with sealing cap																	
D	with turning knob																	
X	without sealing cap																	
Version																		
A	standard																	
C	back pressure compensated																	
Seal material	V	FKM		other seal materials on request														

*Setting pressure must be below the maximum operating pressure.
Preset valves only available with sealing cap (actuation type „F“).
Minimum order > 50 pcs.

Product information

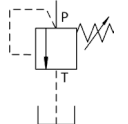
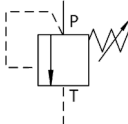
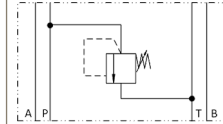
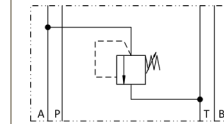
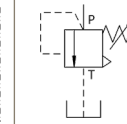
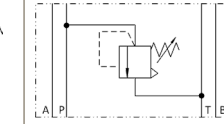
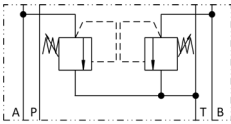
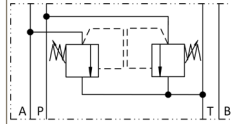
Version	A				C	
Design	E	G	P	A	E	P
Symbol						
Weight	0,18 kg	0,18 kg	1,69 kg	1,69 kg	0,18 kg	1,69 kg
Size	700 bar					
Part-No. sealing cap	4534820	4770566	4535117	4827006	4604645	4604726
Part-No. turning knob	4585182	4763173	4605295	on request	4605370	4605417
Size	1000 bar					
Part-No. sealing cap	4408891	4819339	4408921	on request	4455413	4604846
Part-No. turning knob	4605303	4731402	4605304	on request	4605371	4605419
Design	AB		PA			
Symbol						
Weight	2 kg		2 kg			
Size	700 bar		700 bar			
Part-No. turning knob	4809350		4809352			

Cavity
ADA-model-no.: 4693000

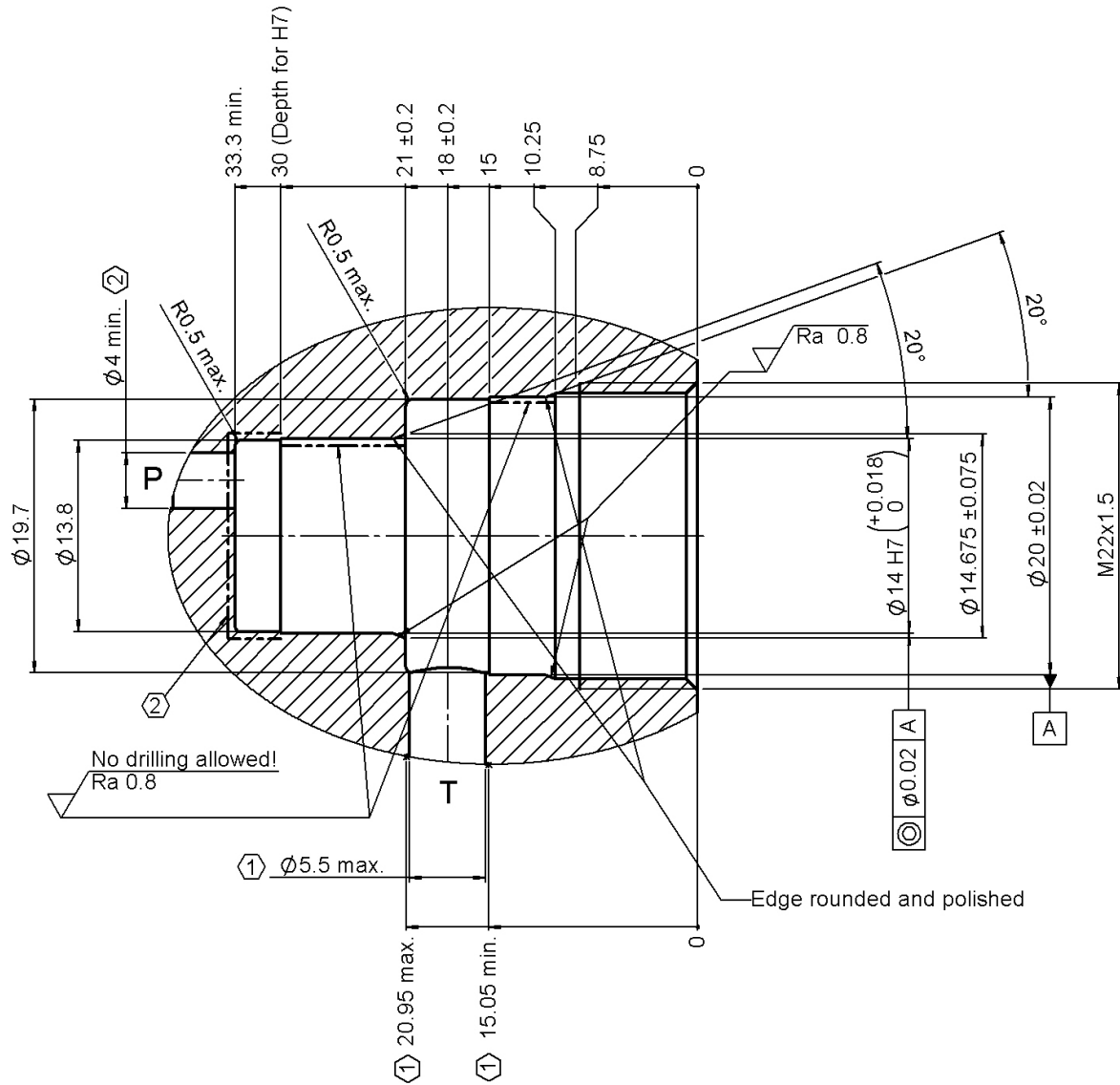

- ① Cross holes are allowed within this range
- ② Within this area, transverse or longitudinal drilling is permitted.

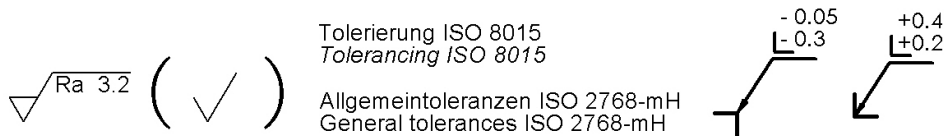

The responsibility of the material design with regard to strength lies with the user

Modular subplate from P to T

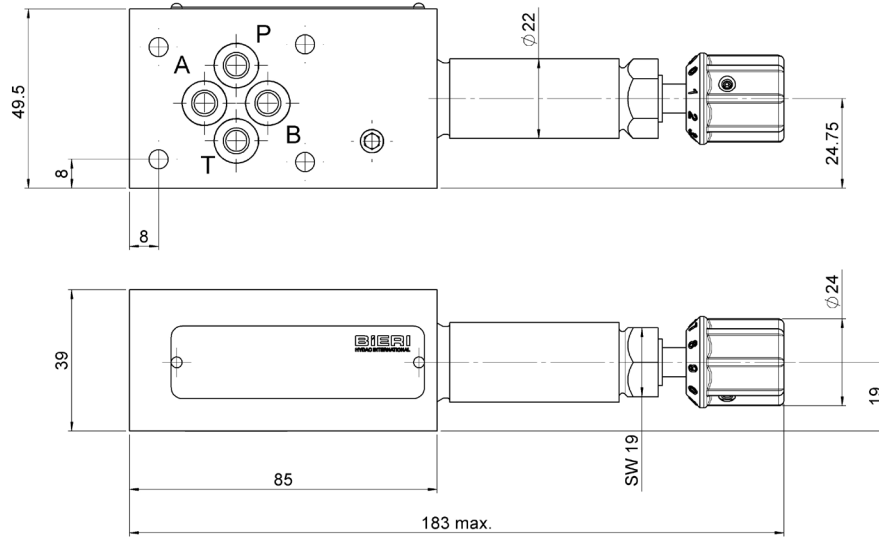

Modular subplate from A to T

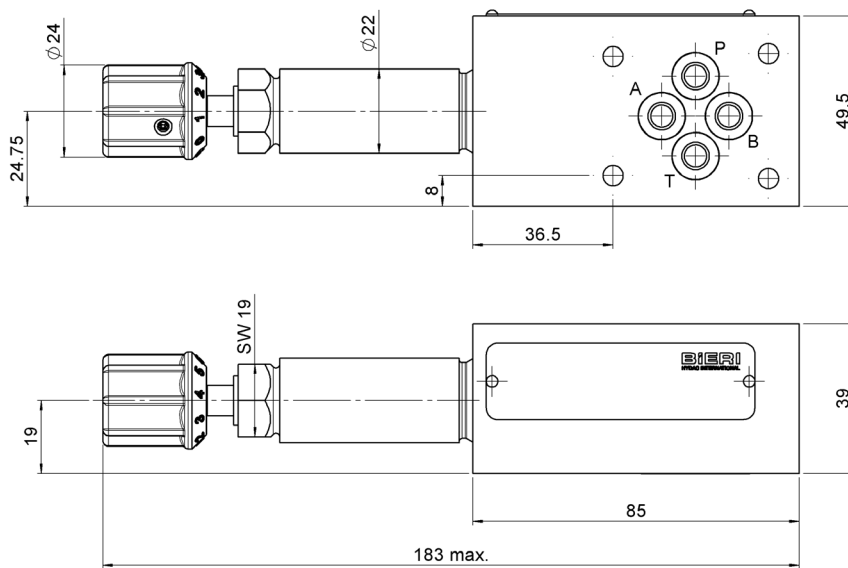

Modular subplate valve from A to T, B to T and P to T, A to T

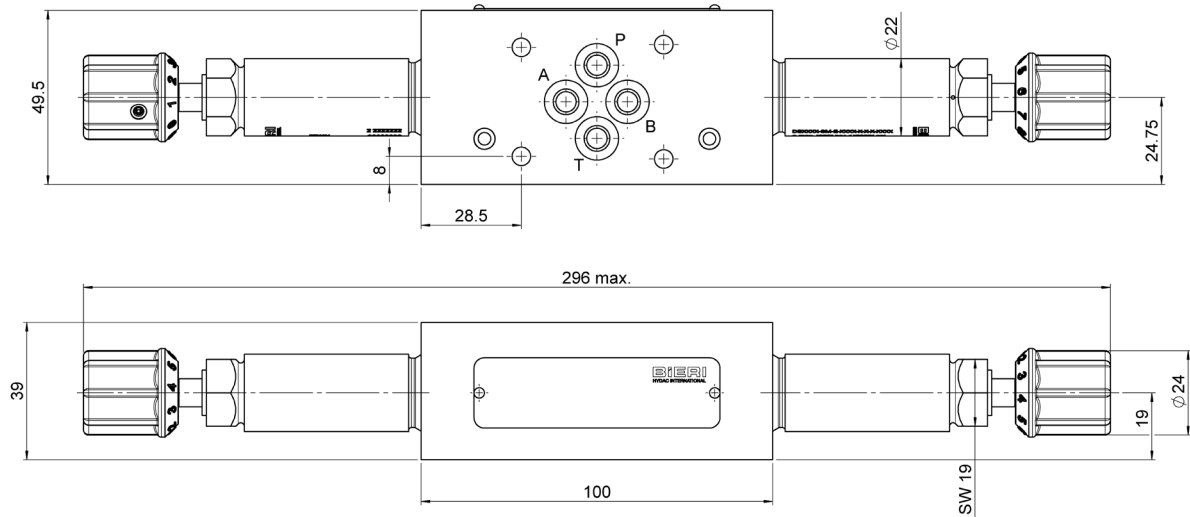

Valve block for in-line mounting

type	max. operating pressure	part No.	dim. d [mm]	dim. D [mm]
VKR-6-DB700/DB500 1/4" with mp	700 bar	4755302	-	-
VKR-6-DB700/DB500 1/4"	700 bar	4648470	1/4"	25.2
VKR-6-DB700/DB500 3/8"	700 bar	4687868	3/8"	28.2
VKR-6-DB1000	1000 bar	4539124	-	-

Dimensional drawing

700 bar

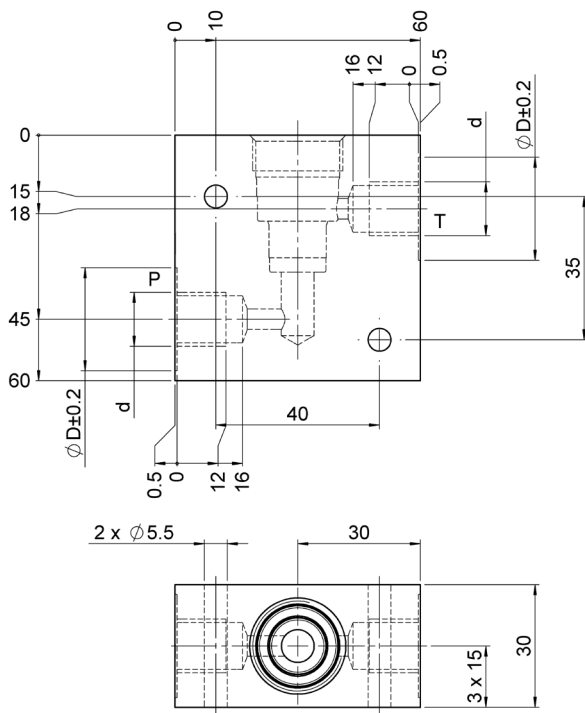

1000 bar

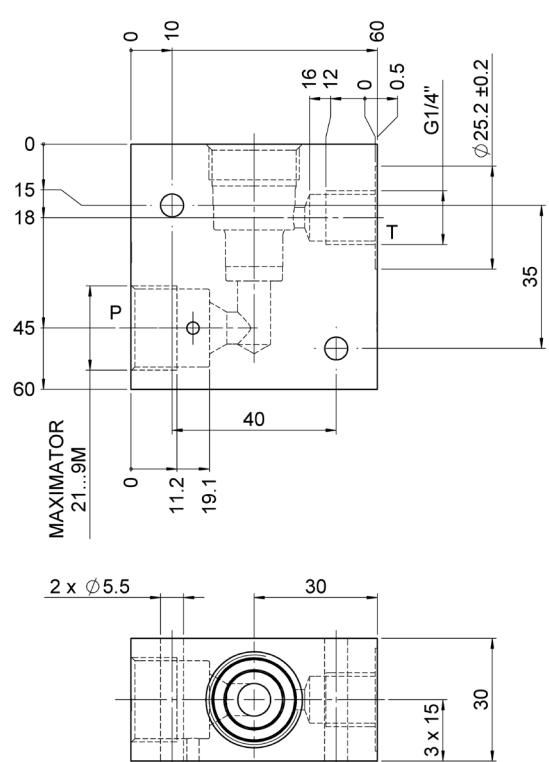

700 bar with mp (measuring port)

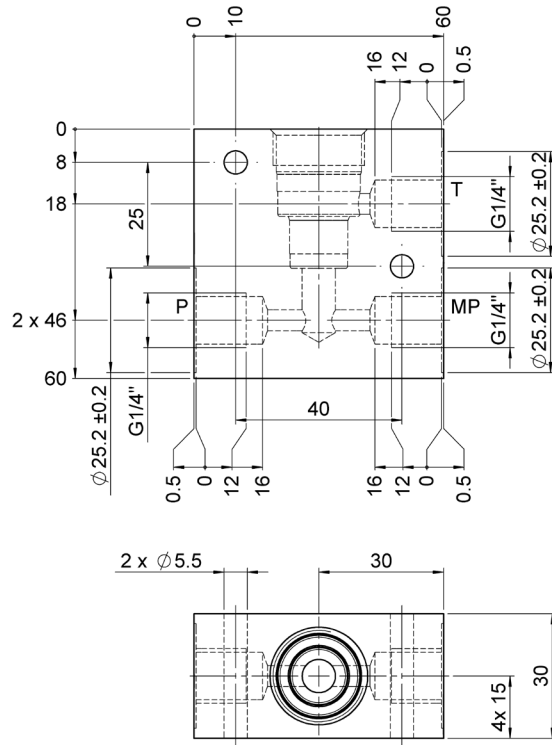

Dimensional drawing with pressure relief cartridge (Cartridge not included in scope of supply)

with sealing cap

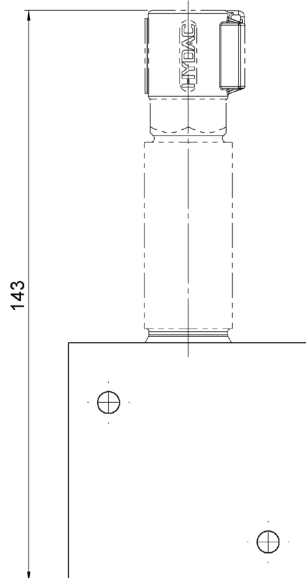

with turning knob

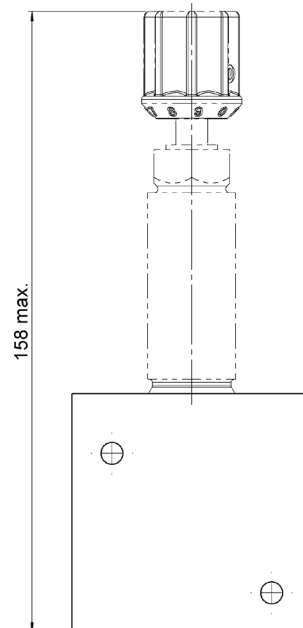

Anschluss "P" mit MAXIMATOR-Verrohrung
Connection "P" with MAXIMATOR piping

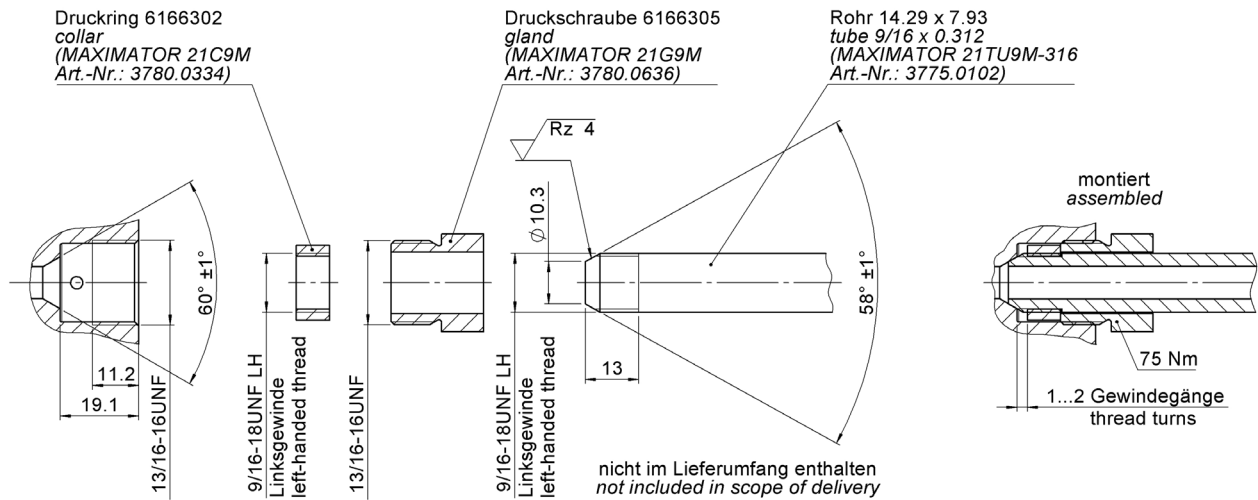

Anschluss "P" mit System-Anschluss G1/4"
Connection "P" with system adapter G1/4"

Accessories

item description	part no.
adapter G1/4" MAXIMATOR	3939573

Anschluss "P" mit System-Anschluss G1/4"
Connection "P" with system adapter G1/4"

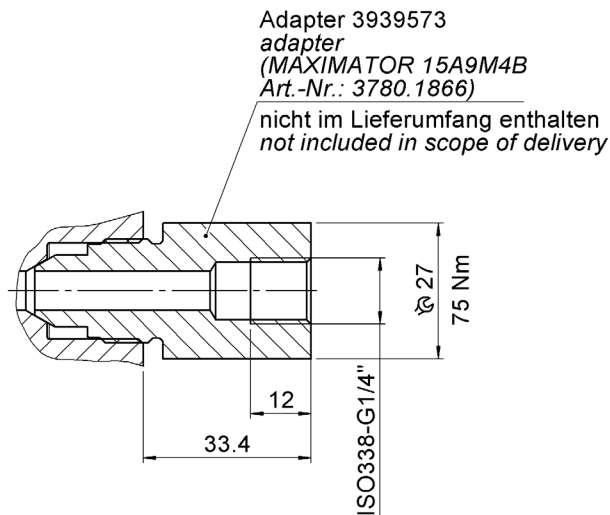

Characteristics

Measured at $v = 32 \text{ mm}^2/\text{s}$, $T = 40^\circ\text{C}$

---- back pressure compensated version with 100bar pressure in the T-connection

